

M3660 OIL MIST COLLECTOR

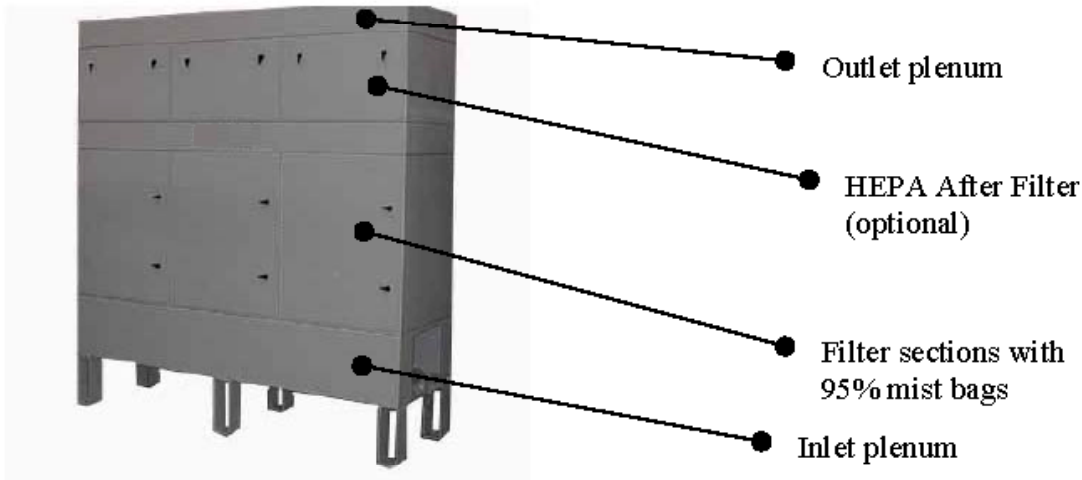

FEATURES & SPECIFICATIONS

DIMENSIONS APPROX:	67"H* x 82"W x 27"D Without HEPA & blower 89"H x 82"W x 27"D With HEPA no blower
WEIGHT APPROX.:	890/1240H lbs. Installed 950/1300H lbs. shipping weight
CABINET:	16 gauge welded steel cabinet with ivory enamel finish.
POWER INPUT:	208/230/460 volt 3 phase
MOUNTING:	Floor mounted
MOTOR:	Heavy-duty motor with sealed ball bearings.
BLOWER:	5.0 HP direct drive rated 3000 CFM @ 5.5" 7.5 HP direct drive rated 4000 CFM @ 4.5" *** Custom Blower / Motor packages available
PREFILTER:	24' x 24" x 4" mist impingers
PRIMARY FILTER:	95% oil mist bags
INSTRUMENTATION:	Dirty Filter Gage – Factory installed pressure gage designed to determine filter replacement cycle.
FILTER ACCESS:	Front load
SOUND LEVELS:	Max 80 dBA at 15 ft., 85 dBA at 9 ft. (5 HP)

STANDARD FEATURES

- Oil mist bags with up to 261 sq. ft. of media and 95% efficiency.
- Quality engineering and workmanship backed by a 3 year parts warranty.
- 5 or 7.5 HP motor blower (not shown)

OPTIONAL FEATURES

- Motor and fan combinations
- Add on carbon, HEPA or electrostatic modules.



For information:
BERRIMAN ASSOCIATES
www.berriman.com
1-800-480-3630

Manufacturer has a policy of continuing product improvement and reserves the right to make changes in design and specification without notice.