

ENVIRONMENTAL REMEDIATION AIR CLEANER

M68P - PORTABLE HEPA AIR CLEANER

The M68P is ideal for remediation or construction projects where control of migratory particulate is required. With airflows of up to 2000 CFM this unit can create a negative pressure environment while the true HEPA controls the particulate to 99.97% efficiency.*



* Outlet duct required for negative pressure mode.

SPECIFICATIONS:

- Cabinet: 16-gauge steel cabinet with a chemical resistant baked enamel, ivory texture coated finish.
- Power Input: 208-240 VAC, 1 Phase, 9 amps
- Motor: 2 HP maintenance-free sealed ball bearings and thermally protected. Adjustable motor sheave allows for field airflow adjustments.
- Blower: Forward curved, ball bearing, belt driven centrifugal blower
- Airflow: Up to 2000 cfm
- Filtration: Pre-filter - 24" x 24" x 4" 35% pleated media
Primary - 24" x 24" x 12" HEPA 99.97% certified efficiency at 0.3 microns
- Casters: 5" Swivel
- Handle: High Impact Plastic
- Dirty Filter Gage: Water monometer tells when filter needs to be changed.

Options:

45 pound carbon module for removing VOCs.

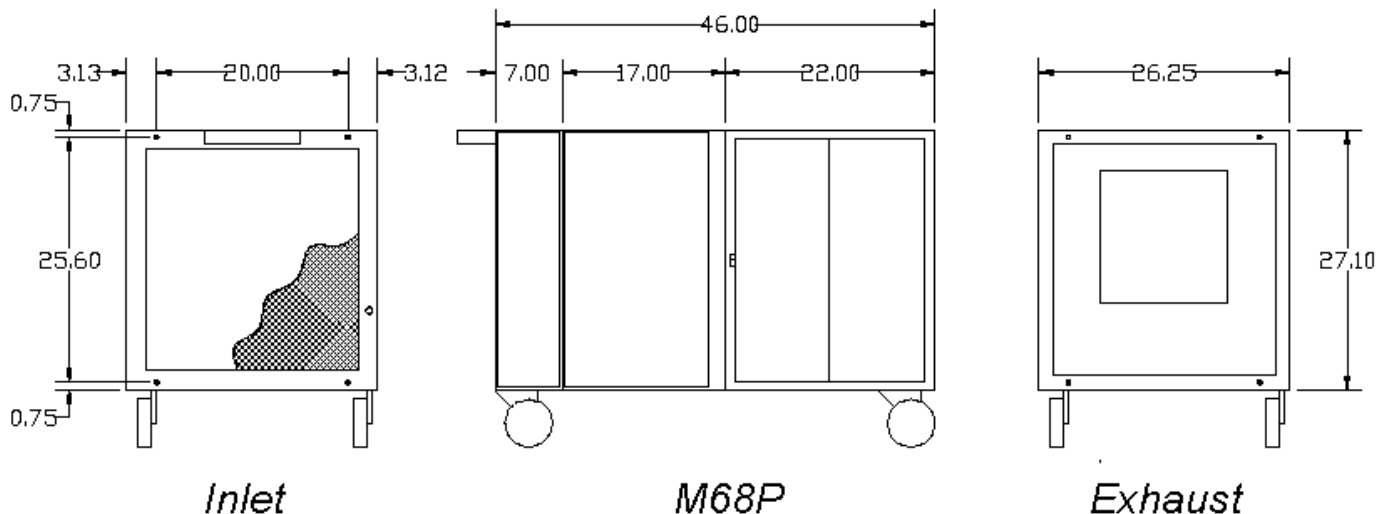

For information:
BERRIMAN ASSOCIATES
www.berriman.com
1-800-480-3630

Manufacturer has a policy of continuing product improvement and reserves the right to make changes in design and specification without notice.