

F115 Ceiling Surface-Mounted Commercial Media Air Cleaner

SPECIFICATION DATA



FEATURES

- Models available with 99.97% HEPA filters or a combination of 95% DOP particulate filters and CPZ sorbent media modules. The filters in both models are more efficient on particles larger and smaller 0.3 micron.
- Single-speed, direct-drive, forward curve blowers/motors deliver up to 600 cfm (1020 cu m/hr).
- Designed to overcome the increase in airflow resistance normally caused by filter loading.
- Light-colored cover complements most ceiling finishes.
- Model available with disposable CPZ™ canister for odor control.

APPLICATION

The F115 Ceiling Surface-Mounted Media Air Cleaner is designed for use in restaurants, conference rooms, lounges and offices where overhead air cleaning is required. The F115 uses direct-drive, forward curve blowers/motors with High Efficiency Particulate Arrestance (HEPA) filters or a combination of 95% DOP (Di-Octyl Phthalate) and CPZ™ (Carbon Potassium Permanganate and Zeolite) sorbent media cartridges for contamination reduction in an enclosed area.

SPECIFICATIONS

Models:

- F115A Ceiling Surface-Mounted Media Air Cleaner with 99.97% HEPA filters; without CPZ canisters.
- F115C Ceiling Surface-Mounted Media Air Cleaner with 95% DOP filters; with CPZ disposable canisters.

Color:

White plastic cabinet and cover.

Electrical Ratings:

120V, 60 Hz, 1PHS, 7.2A; 220/240V, 50/60 Hz, 1PHS, 3.6A.

Electrical Connections:

J-box hardwired on side and top wired inlet.

Blowers/Motors:

Single-speed, direct-drive blowers/motors.

Air Volume:

600 cfm (1020 cu m/hr).

Dimensions:

See Fig. 1.

Further Information:
BERRIMAN ASSOCIATES
1-800-480-3630
www.berriman.com

F115 CEILING SURFACE-MOUNTED COMMERCIAL MEDIA AIR CLEANER

Weight:

F115A: 65 lb (29.5 kg).
F115C: 64 lb (29 kg).

Controls:

Direct-wired (optional remote mounted On/Off switch).

Sound Level at 3.3 ft (1m):

52 to 56 dBA.

Approvals:

Underwriters Laboratories Inc. Listed.
Canadian Standards Association Certified.

Replacement Parts:

32000206 99.97% High Efficiency Particulate Arrestance (HEPA) Filter (4 required) for F115A1064.
32000217 95% DOP Particle Filter (4 required) for F115C1005.
32000229 Prefilters (Box of 4).
32000230 40-Pack Prefilter (10 Boxes of 4).
32000232 CPZ Canister (4 Required) for F115C1005.

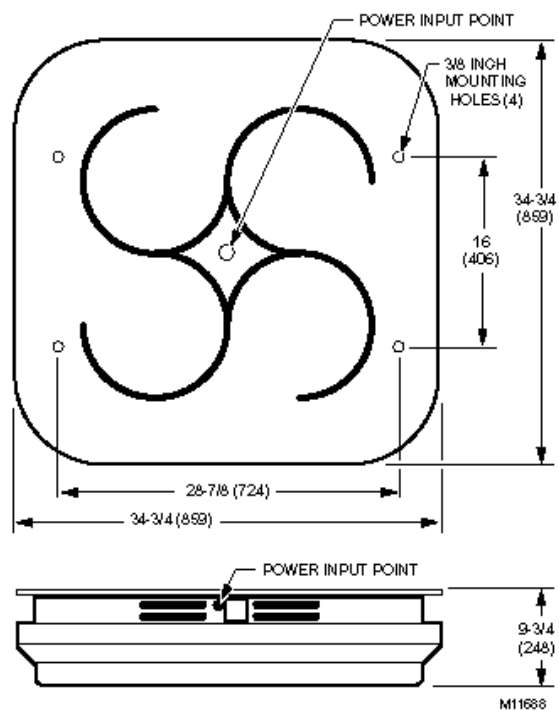

Fig 1. F115 dimensions In In. (mm).

Further Information:
BERRIMAN ASSOCIATES
1-800-480-3630
www.berriman.com

Honeywell

The Honeywell Trademark is used under license from Honeywell Intellectual Properties, Inc.